

# 4535 X-RAY INSPECTION

Explosives, Weapons and Contraband

SINGLE SOURCE, MULTI-ENERGY

X-RAY INSPECTION



Lighter and shorter than our best-selling full-size scanner, the 4535 packs all the speed, power and detection capability of our flagship multi-energy models into a sub-compact design. Sized for inspecting mail, hand carried objects, personal items, clothing and shoes, the 4535 meets the throughput demands of high-traffic settings. An intuitive operator interface makes this unit suitable for both security professionals and non-technical personnel.

- > The performance and features of larger, heavier systems in a compact cabinet design
- > Fits through narrow doorways and in standard elevators
- > Easy to use operator interface
- > Full suite of image enhancement tools

#### APPLICATIONS:

- > Mail Screening
- > Executive Offices
- > Private Security
- > VIP Diplomatic Security
- > High-risk Event Security

# 4535 SPECIFICATIONS

X-RAY INSPECTION

## PHYSICAL DETAILS

<b>Tunnel Size:</b>	45.0 x 35.0 cm 17.7 x 13.8 in. (W x H)
<b>Dimensions:</b>	85.5 x 66.4 x 107.5 cm 33.7 x 26.2 x 42.3 in. (L x W x H)
<b>Weight:</b>	200 kg (440 lbs.) uncrated 268 kg (590 lbs.) crated
<b>Construction:</b>	Unibody heavy gauge epoxy painted steel construction with stainless steel and aluminum trim and accessories; non-marking casters
<b>Temperature:</b>	0° to 40°C (32° to 104°F)
<b>Humidity:</b>	20% to 95%, non-condensing
<b>Storage:</b>	To 65°C (149°F)
<b>Power Consumption:</b>	< 0.7 kVA; 100, 120, 200, 220, 240, 250 volts AC +10%; < 7 amps 100, 120 volts AC ±10%; < 3.5 amps 200, 220, 240, 250 volts; all at 50 or 60 Hz

## X-RAY GENERATOR

<b>X-ray Tube Head:</b>	Self-contained
<b>High Voltage Rating:</b>	100 kV, operating at 90 kV
<b>Duty Cycle:</b>	100% with sealed oil bath cooling
<b>Beam Orientation:</b>	Diagonal (80° beam divergence)
<b>Dose per Exam:</b>	0.1 mR (1 µSv)

## INSPECTION CAPABILITIES

<b>Material Penetration:</b>	10–11 mm (0.39–0.43 in.) steel
<b>Contrast Sensitivity:</b>	Over 2 million color tones standard
<b>Resolution:</b>	40 AWG wire
<b>Processing:</b>	32-bit adaptive image processing with minimum 1 Gbytes+ memory; 2.2 GHz+ dual core processor; video processing using next generation graphical processing unit architecture with 550MHz+ GPU clock, 512Mbyte+ video memory and 32+ stream processing cores
<b>Conveyor Speed:</b>	24.0 cm (9.4 in.) per second 14.6 m (48 ft.) per minute
<b>Pulling Weight:</b>	150 kg (331 lbs.)
<b>Film Safety:</b>	Guaranteed for high-speed film up to ISO 1600 (33 DIN)

## DETECTORS

L-shaped detector for 100% package screening  
Surface mounted, multilayer, fully integrated, high frequency solid state detectors using high speed processors and Pentium 4 image processing

## VIDEO

19" Color LCD monitor, 1280 x 1024 video card

## STANDARD FEATURES

- autoSoft operating system
- Full-size operator control panel (OCP) with touchpad navigation
- autoTracking guided conveyor belt system
- Entrance tunnel extension
- High/low density stripping
- Organic/inorganic stripping
- Color; reverse B/W imaging
- Interactive help screens
- 128x Smart Zoom
- D-SCAN
- Dark and light enhance
- RealClear
- autoDensAlert
- autoOutline
- autoSensing
- autoScale
- autoCal
- autoImage recall (10 images)
- Z-SCAN
- Save screen to USB
- Adjustable zoom preview window

## OPTIONS

- Loading or exit rollerbeds
- Conveyor extensions
- Exit tunnel extension
- Parcel slide
- Tropical humidity kit
- DVD drive
- autoShieldAlert
- autoZ display
- Image archiving (500K)
- Built-in training
- Level 1, 2 and 3 networking
- User management
- STI Viewer software for archived image analysis
- Locking metal OCP cover
- Variable height OCP mount
- Dual and larger monitors
- Monitor platform
- Locking monitor garage
- Laser printer
- Console desk
- kV, mA meter
- Power conditioner, or UPS
- Optical X-ray on/off sensor
- Footpad
- Item counter
- Remote operation
- autoArchive

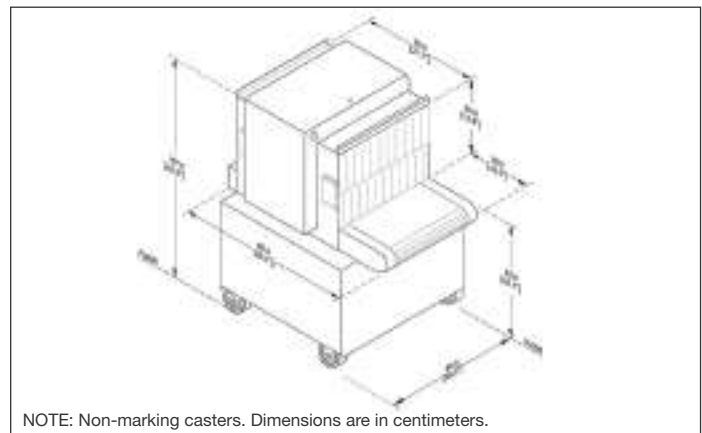

NOTE: Non-marking casters. Dimensions are in centimeters.



World Headquarters  
2 Gardner Road  
Fairfield NJ 07004 USA

Tel. 1 973.276.6000  
Toll-free 1 800.231.6414  
Fax. 1 973.276.6162  
info@autoclear.com

ISO 9001-2008 REGISTERED

© 2011-2016 Autoclear. CheckGate®, Control Screening®, Dynavision®, HandWand® and Scintrex® are among our many registered trademarks. All rights reserved. Autoclear reserves the right to update this information presented in this document at any time, without notice.